



US 20090140959A1

(19) **United States**

(12) **Patent Application Publication**

Nam et al.

(10) **Pub. No.: US 2009/0140959 A1**

(43) **Pub. Date: Jun. 4, 2009**

(54) **DRIVING APPARATUS FOR ORGANIC ELECTRO-LUMINESCENCE DISPLAY DEVICE**

(30) **Foreign Application Priority Data**

Nov. 7, 2007 (KR) 10-2007-0112916

(76) Inventors: **Woo-Jin Nam**, Gyeonggi-Do (KR);
In-Su Joo, Gyeonggi-Do (KR)

Publication Classification

(51) **Int. Cl.**
G09G 3/30 (2006.01)

(52) **U.S. Cl.** 345/76

Correspondence Address:
MCKENNA LONG & ALDRIDGE LLP
1900 K STREET, NW
WASHINGTON, DC 20006 (US)

(57) **ABSTRACT**

(21) Appl. No.: **12/289,912**

Disclosed is an apparatus that prevents a degradation of image quality due to a deterioration of a driving apparatus in an organic electro-luminescence display device.

(22) Filed: **Nov. 6, 2008**

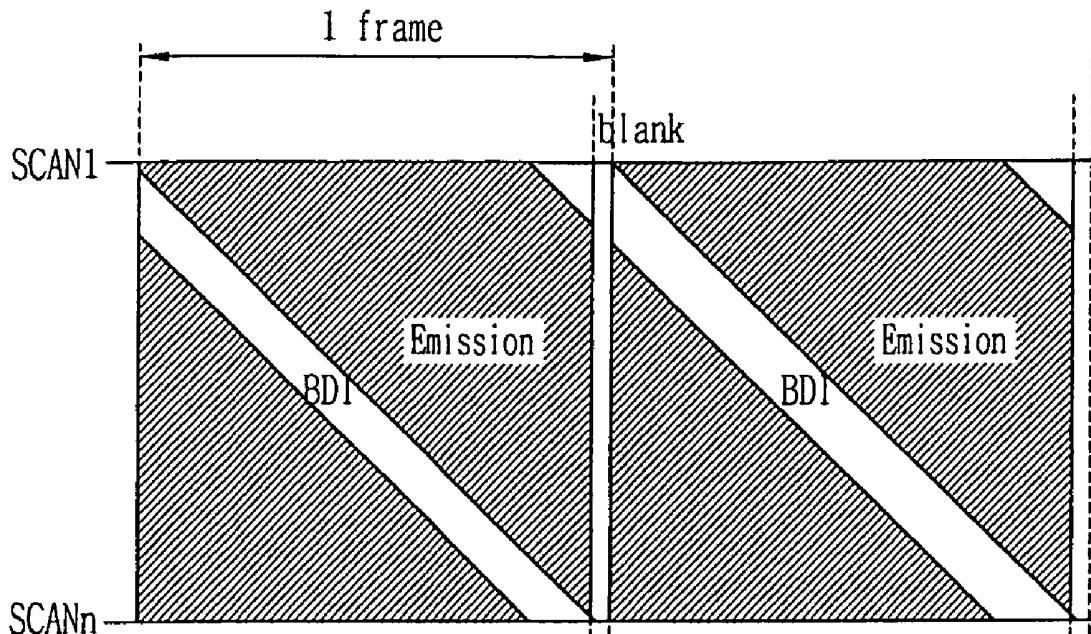

FIG. 1
RELATED ART

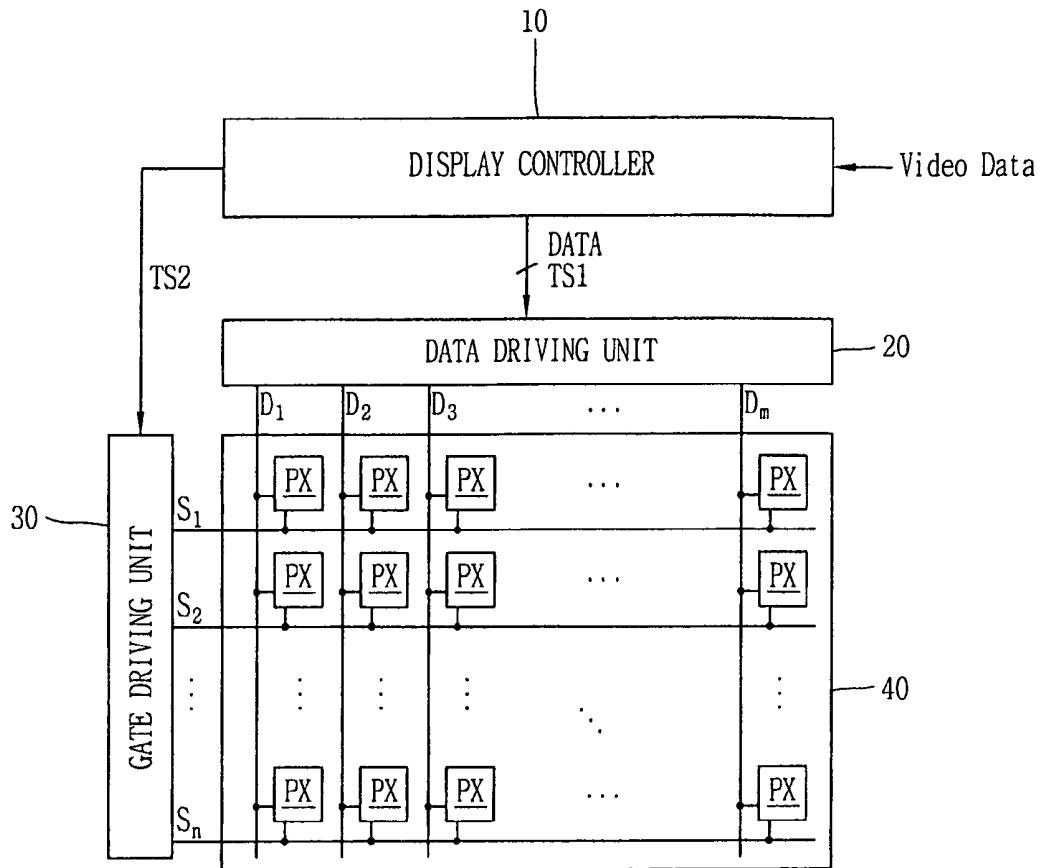

FIG. 2
RELATED ART

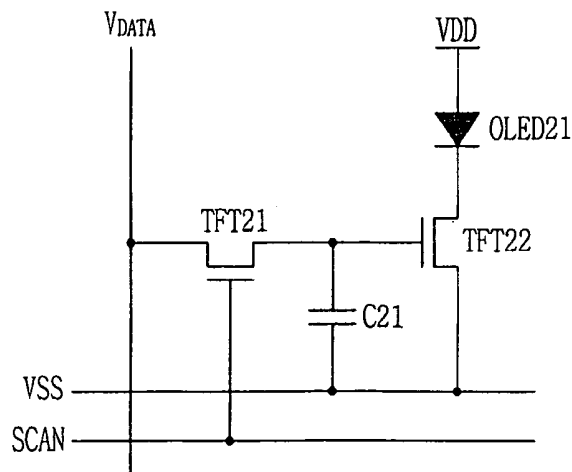

FIG. 3
RELATED ART

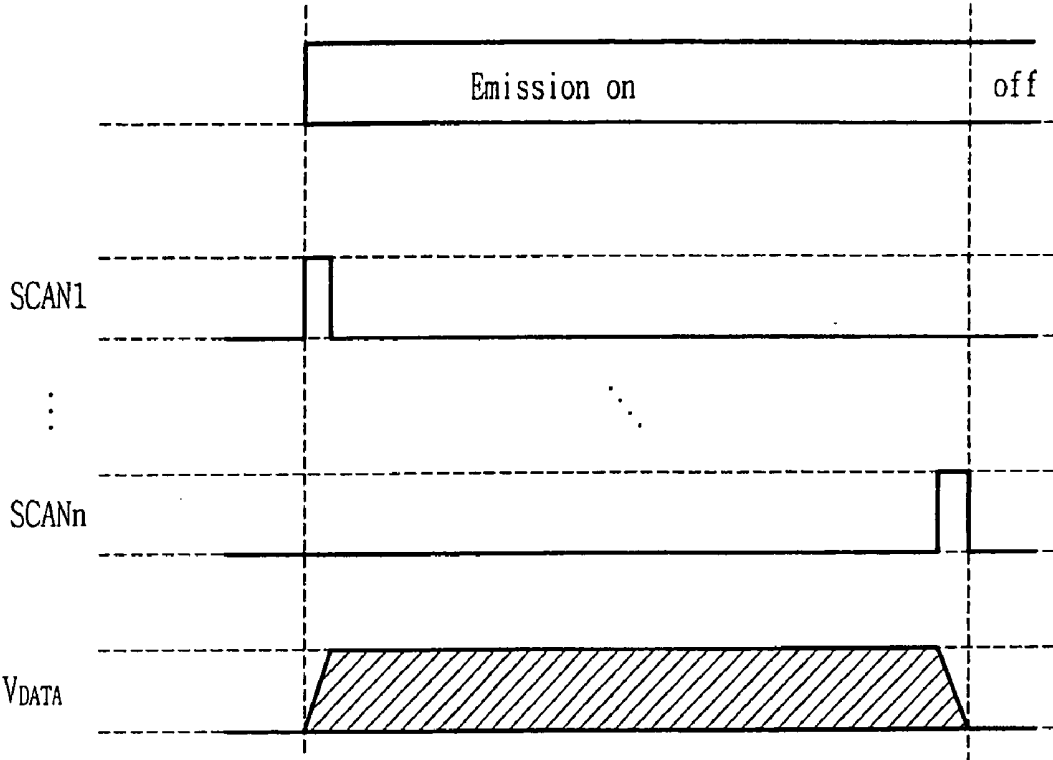

FIG. 4

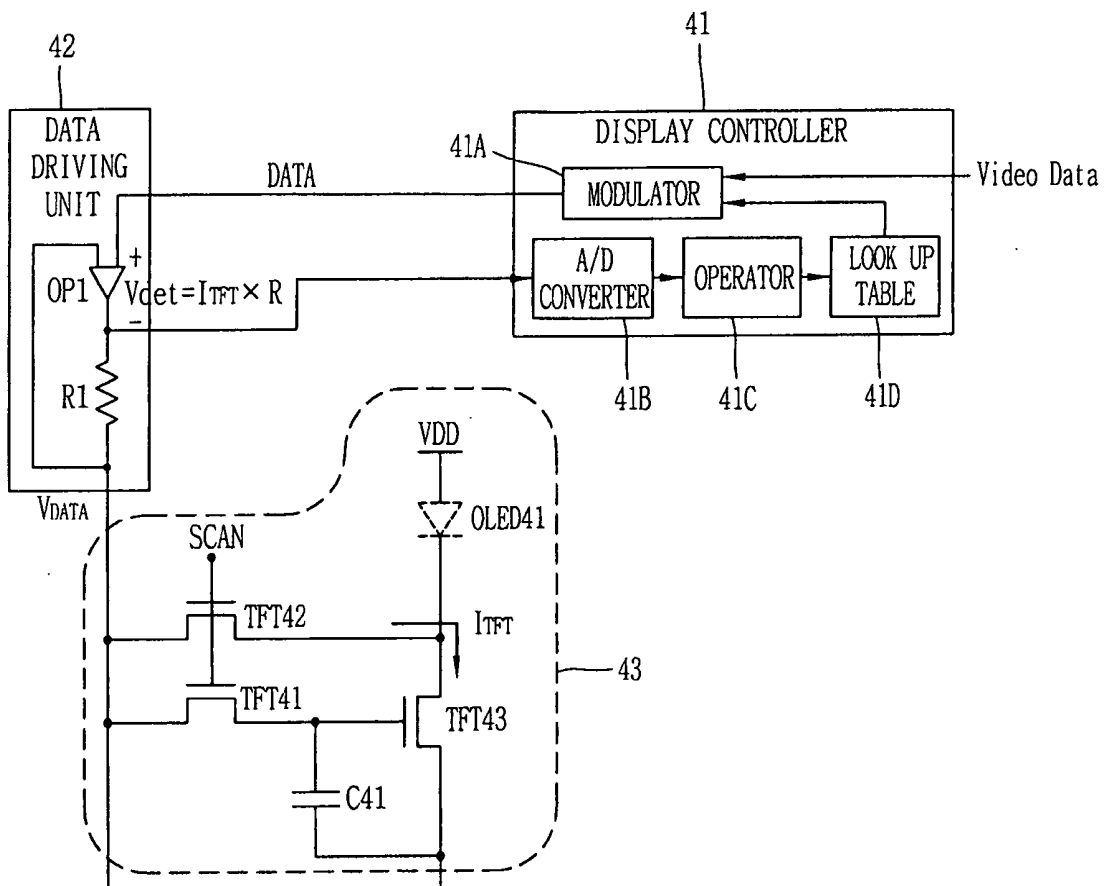

FIG. 5

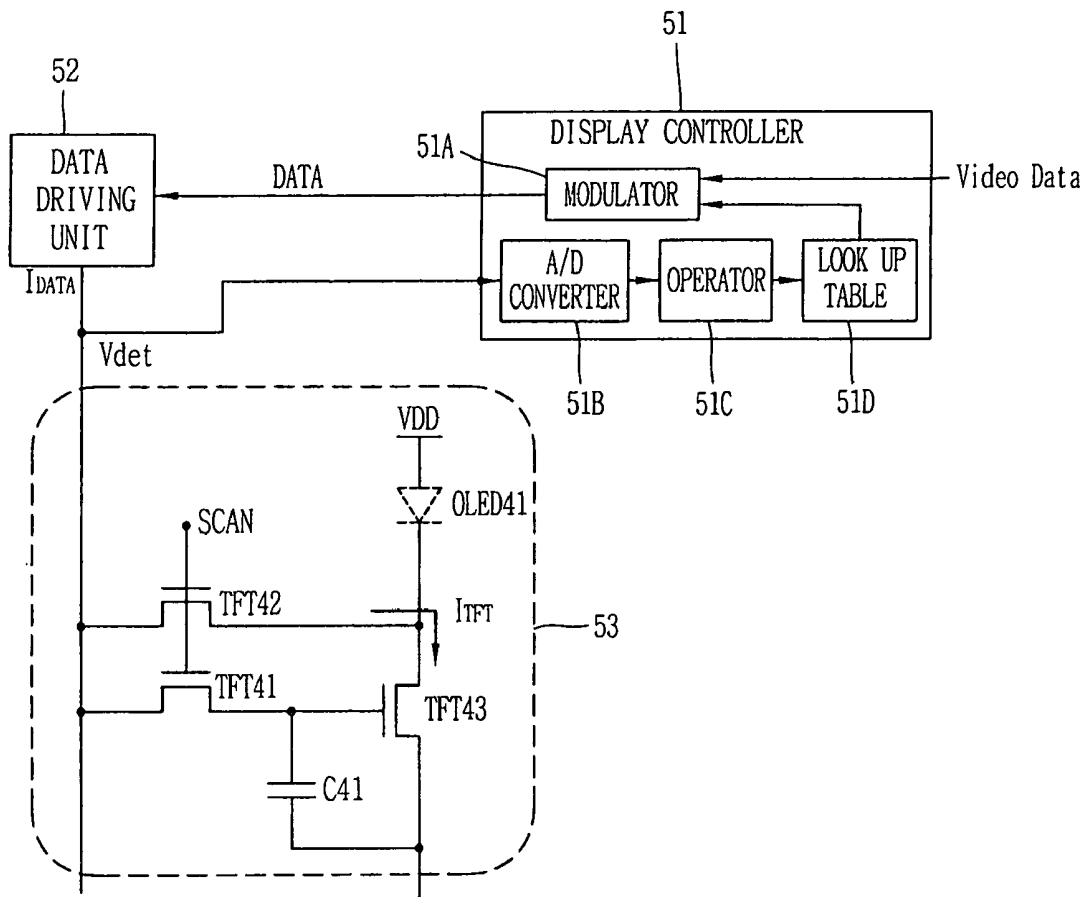

FIG. 6A

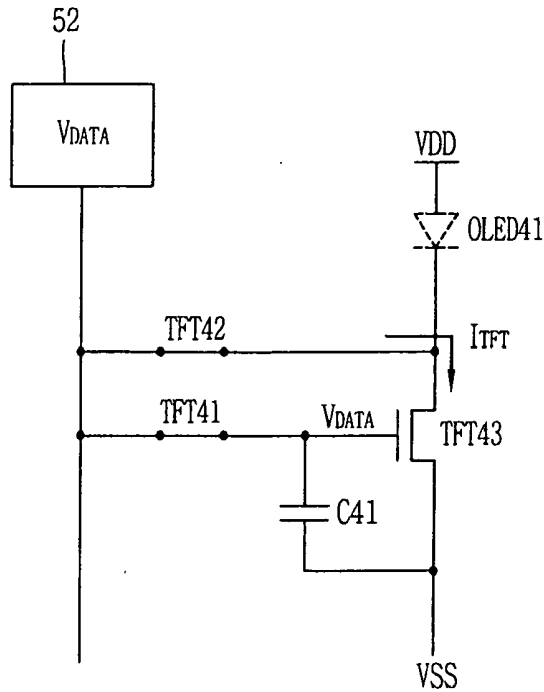

FIG. 6B

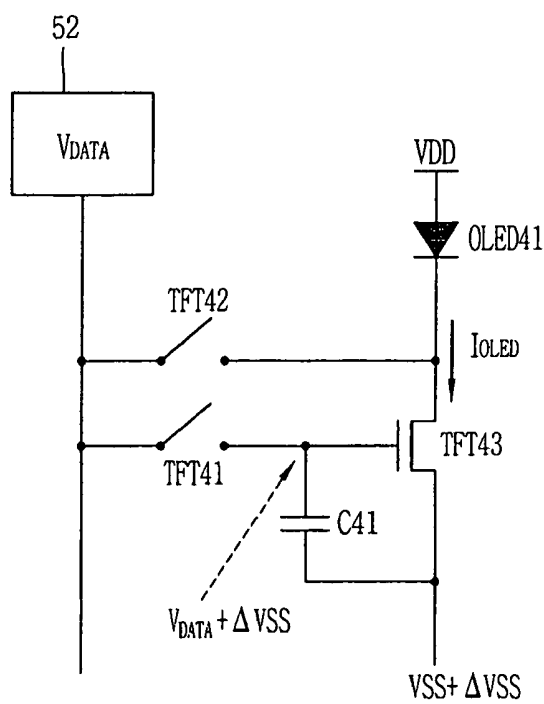

FIG. 7

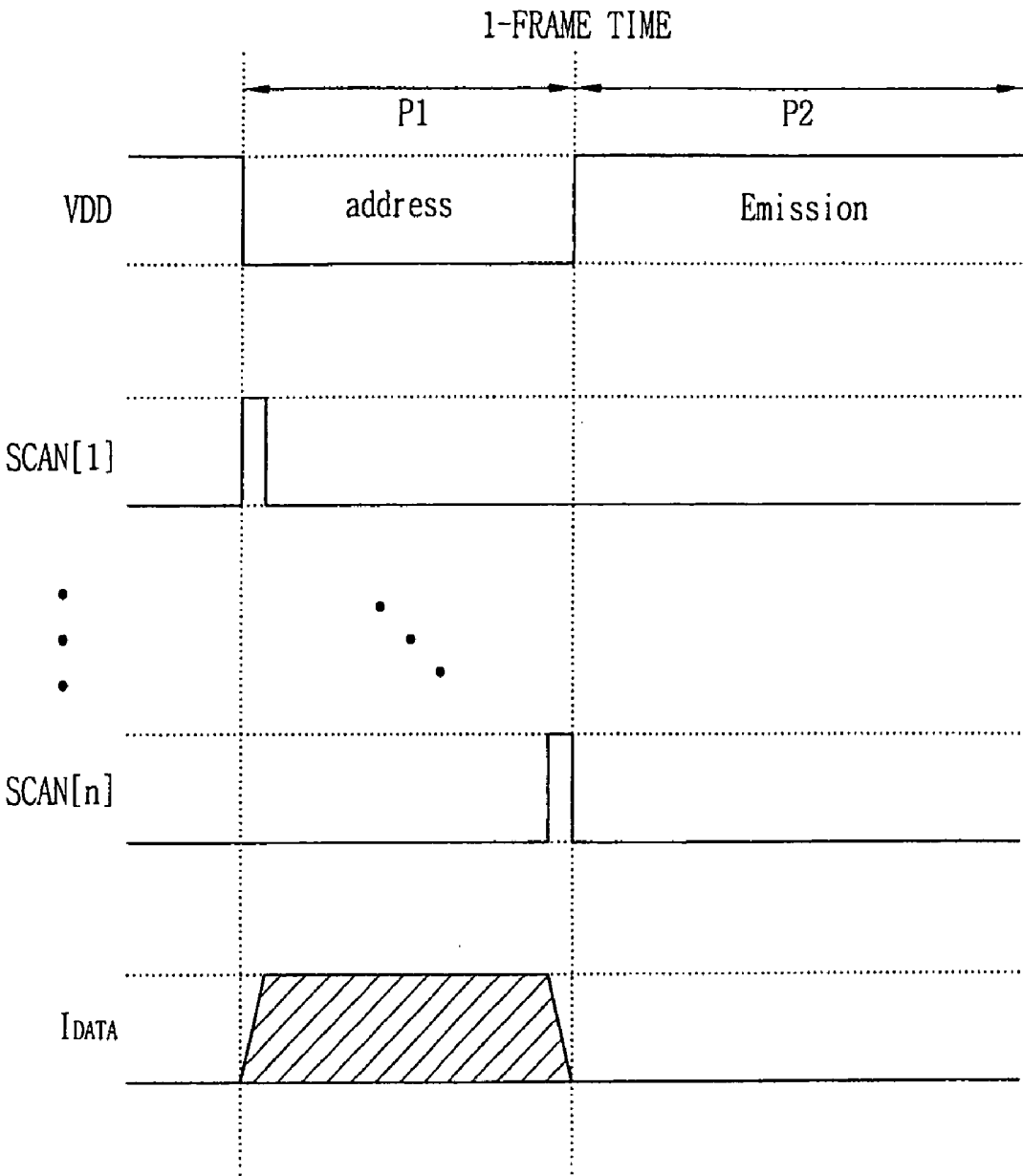

FIG. 8A

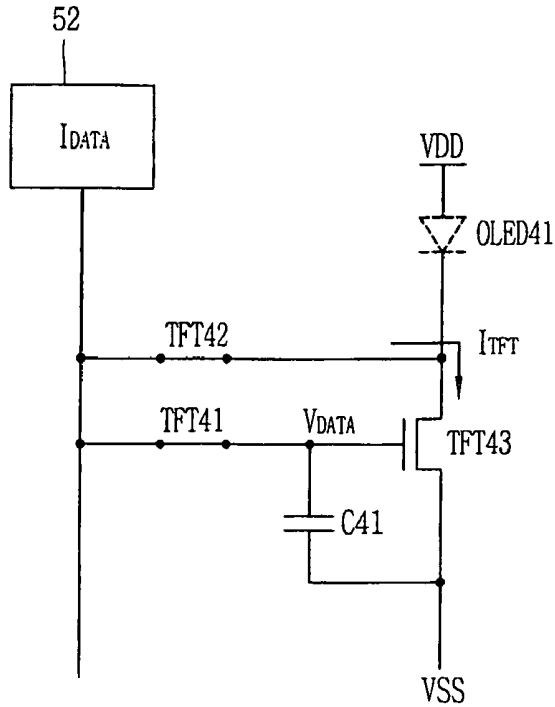

FIG. 8B

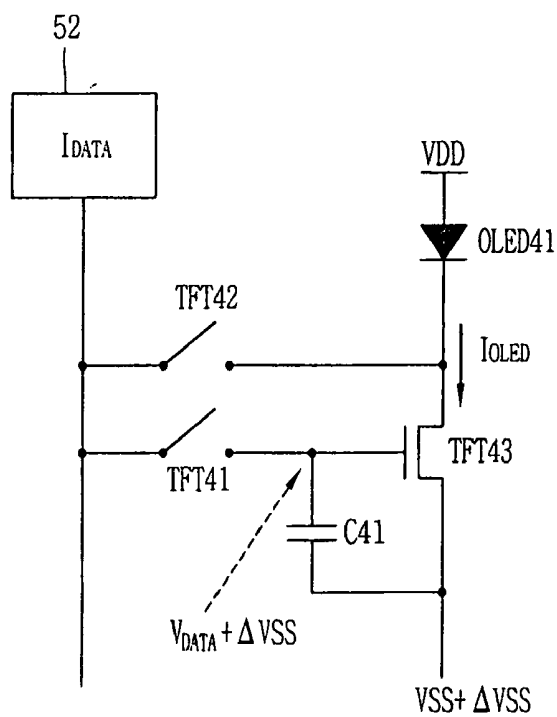

FIG. 9

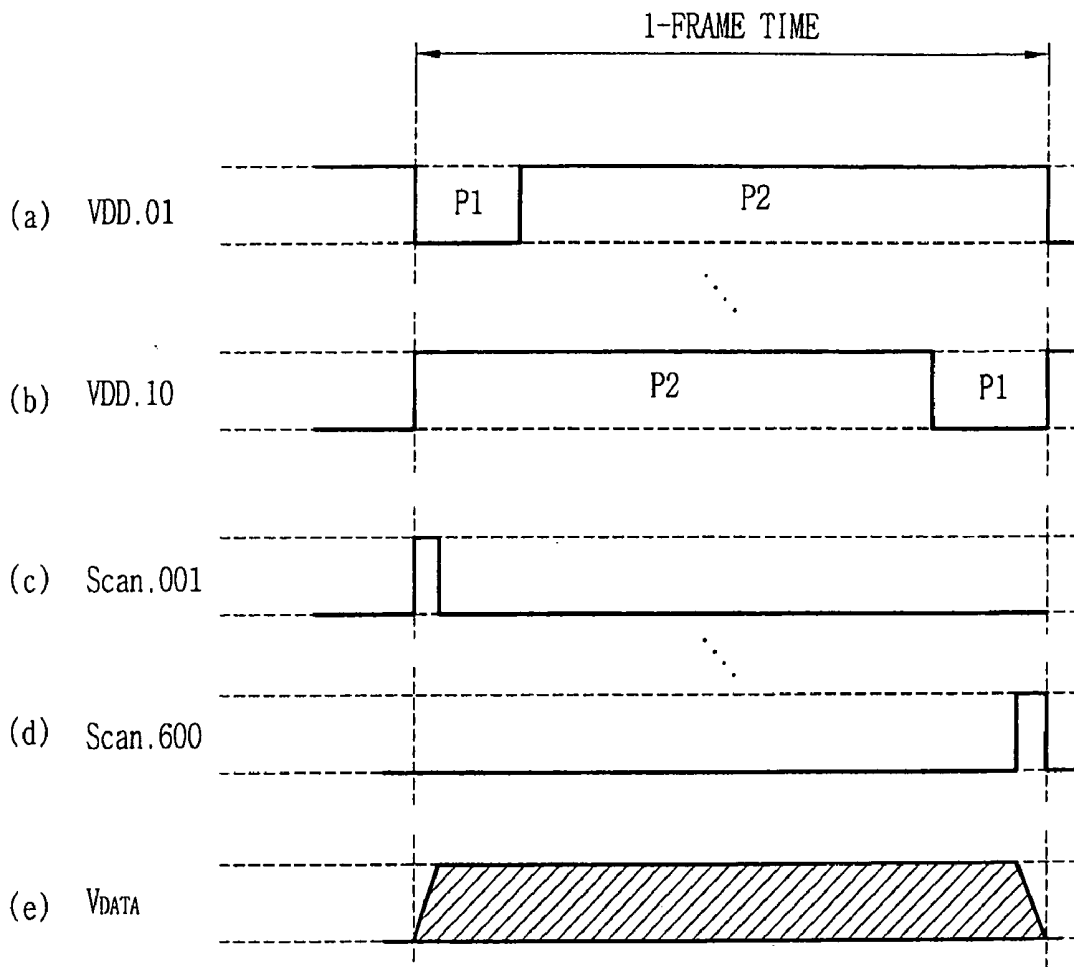

FIG. 10

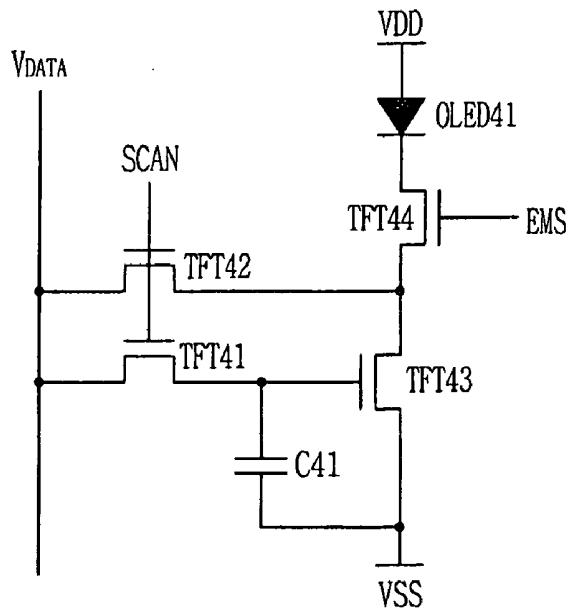

FIG. 11

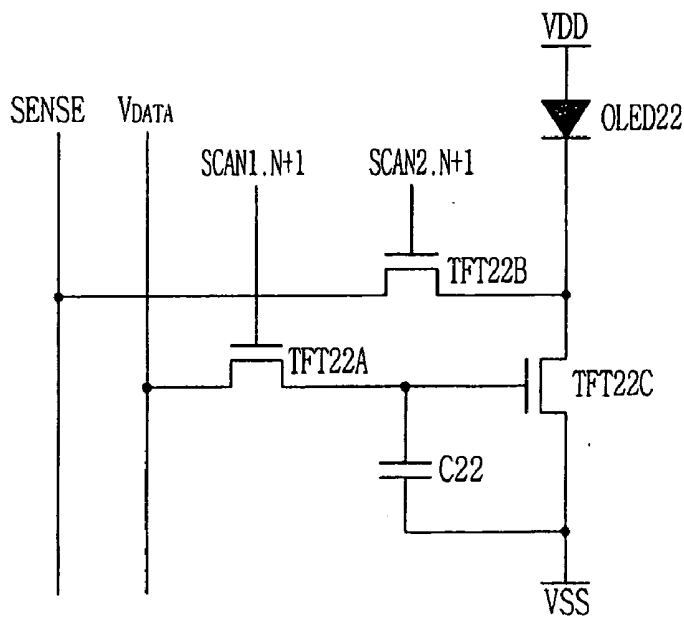

FIG. 12

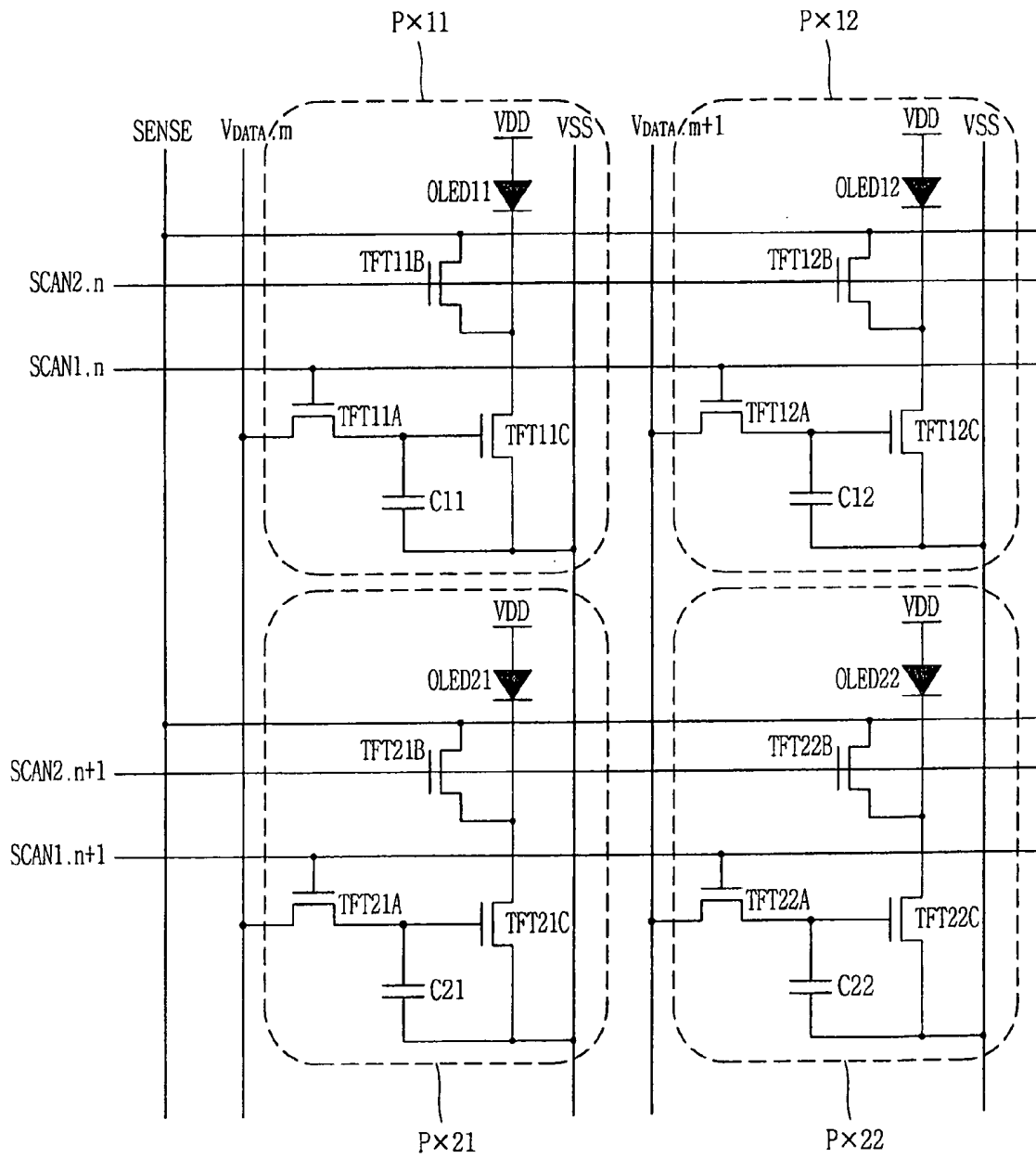

FIG. 13A

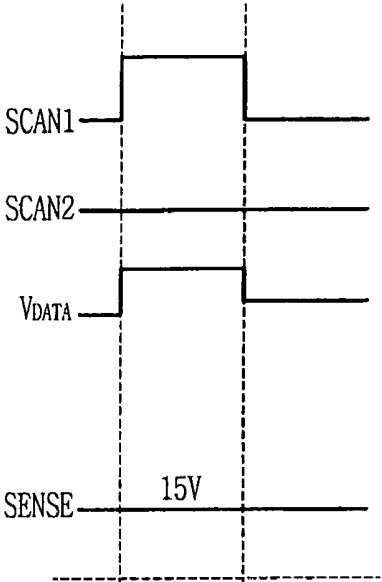

FIG. 13B

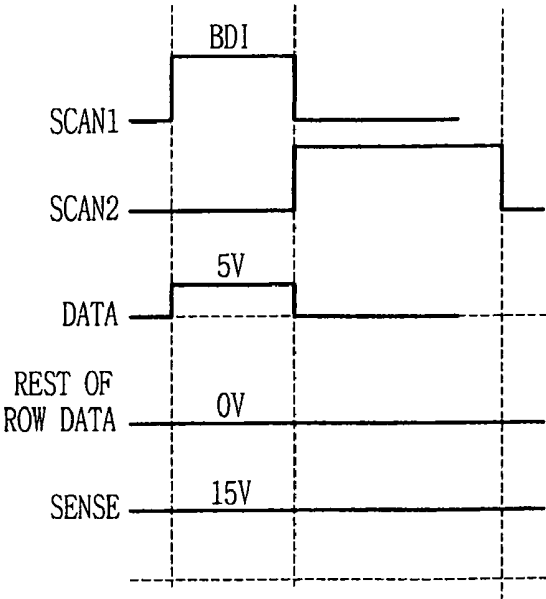
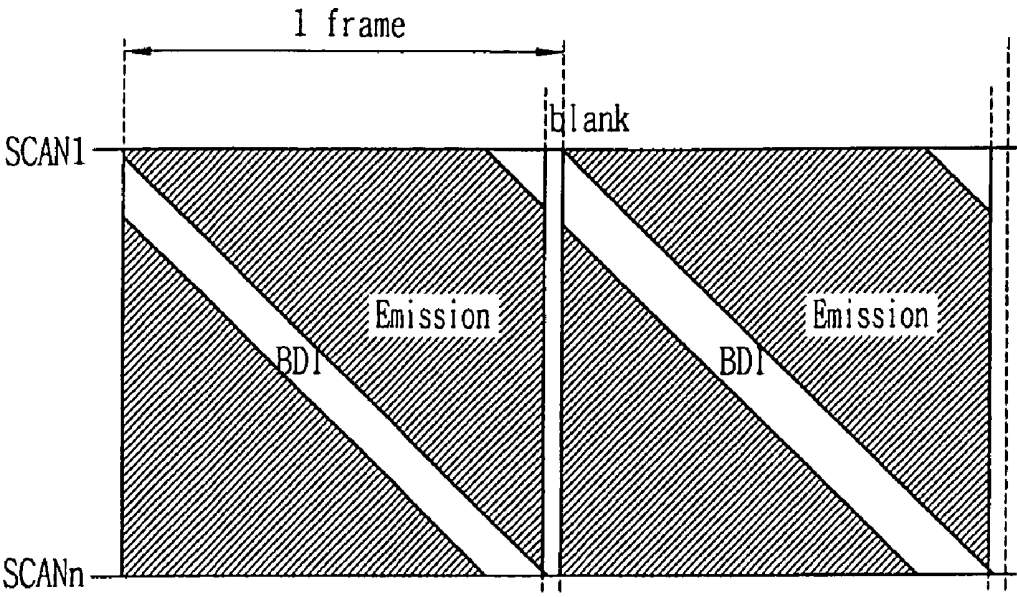

FIG. 14



DRIVING APPARATUS FOR ORGANIC ELECTRO-LUMINESCENCE DISPLAY DEVICE

[0001] This application claims the benefit of Korean Application No. 10-2007-0112916, filed on Nov. 7, 2007, which is incorporated by reference for all purposes as if fully set forth herein.

BACKGROUND OF THE INVENTION

[0002] 1. Field of the Invention

[0003] The present invention relates to pixel driving of an organic electro-luminescence display device, and particularly, to a pixel driving apparatus of an organic electro-luminescence display device capable of avoiding a degradation of image quality due to a deterioration of a driving apparatus of an organic electro-luminescence display device.

[0004] 2. Discussion of the Related Art

[0005] In general, an organic electro-luminescence display device is one type of flat panel display device. When a voltage is applied to two electrodes which face each other with an organic emitting layer interposed therebetween, electrons injected from one electrode and holes injected from the other electrode form pairs in the organic light emitting layer. Accordingly, luminescent molecules of the organic light emitting layer are excited to thereafter return to a ground state, thus to create energy, and such energy is emitted by the organic electro-luminescence display device. The organic electro-luminescence display device capable of emitting light as mentioned above attracts attention as a next generation display device because of its high visibility, light weight, thin configuration, and low voltage driving.

[0006] Depending on an existence of a switching device disposed in a unit pixel on an organic luminescence display panel, the organic electro-luminescence display device may be divided into an active-matrix type organic electro-luminescence display device and a passive-matrix type organic electro-luminescence display device.

[0007] FIG. 1 is a block diagram of an organic electro-luminescence display device according to the related art. As shown in FIG. 1, the organic electro-luminescence display device includes a display controller 10 for generating first and second timing signals TS1 and TS2 by receiving original video data from the exterior and a control signal for the data so as to output the first timing signal TS1 and the image signal DATA to a data driving unit 20 and output the second timing signal TS2 to a gate driving unit 30, the data driving unit 20 for outputting data voltages to data lines D1~Dm on an organic electro-luminescence display panel 40, responsive to the image signal DATA inputted from the display controller 10, the gate driving unit 30 for receiving the second timing signal TS2 from the display controller 10 to sequentially output scan signals for driving scan lines S1~Sn on the organic electro-luminescence display panel 40, and the organic electro-luminescence display panel 40 having OLED pixels PX arranged in a matrix at intersections between the scan lines S1~Sn and the data lines D1~Dm.

[0008] The pixels of the active-matrix type organic electro-luminescence display device may be divided into voltage programming type pixels, current programming type pixels and digital driving pixels.

[0009] FIG. 2 is a view showing a driving circuit of pixels PX arranged on the organic electro-luminescence display

panel 40 of FIG. 1. As shown in FIG. 2, the driving circuit includes a switching transistor TFT21 driven by a scan signal SCAN applied via a scan line for transferring a data voltage V_{DATA} applied via a data line to a storage capacitor C21, the storage capacitor C21 connected between a gate terminal of a driving transistor TFT22 and a terminal for a low power voltage Vss for charging the data voltage VDATA, the driving transistor TFT22 for supplying a driving current corresponding to the data voltage V_{DATA} charged by the storage capacitor C21 to an organic light emitting diode OLED21, and the OLED21 having an anode connected to a terminal for a high power voltage VDD and a cathode connected to a drain of the driving transistor TFT22, for emitting light with a brightness corresponding to the driving current. Here, the transistors TFT21 and TFT22 may be implemented as N-channel thin film transistors (TFTs).

[0010] An operation of the related art pixel driving circuit having such configuration will be described with reference to FIG. 3.

[0011] The display controller 10 receives original video data provided from the exterior and a control signal for the data, thus to generate first and second timing signals TS1 and TS2. The display controller 10 then outputs the first timing signal TS1 and an image signal DATA to the data driving unit 20, and the second timing signal TS2 to the gate driving unit 30.

[0012] Positive scan signals SCAN1~SCANn, as shown in FIG. 3, are sequentially supplied per every frame to the scan lines S1~Sn on the electro-luminescence display panel 40 from the gate driving unit 30, and accordingly, the pixels PX on the corresponding scan lines (horizontal lines) are driven at each time of the supply. FIG. 2 illustrates one exemplary pixel among plural pixels PX (including a driving circuit) connected to an arbitrary scan line.

[0013] The switching transistor TFT21 is turned on by the corresponding scan signal among the scan signals SCAN1~SCANn. Here, the data voltage V_{DATA} supplied from the data driving unit 20 via the corresponding data line among the plural data lines D1~Dm is charged in the storage capacitor C21 via the switching transistor TFT21, to thusly be maintained until before an emission period.

[0014] The driving transistor TFT22 is turned on by the data voltage V_{DATA} charged in the storage capacitor C21, and accordingly a positive current corresponding to the data voltage V_{DATA} flows via the OLED21, thus to allow the OLED21 to emit light with the corresponding brightness.

[0015] On the other hand, upon driving the organic electro-luminescence display panel 40 implemented as an amorphous silicon TFT (a-SI:H TFT), a threshold voltage V_{th} of the driving transistor TFT22 is shifted. In this case, the OLED21 does not normally emit light, causing a lowering of image quality. Such shift of the threshold voltage V_{th} may typically be caused by the data voltage V_{DATA} applied to a gate node of the driving transistor TFT22 of the pixel driving circuit.

[0016] Hence, researches have recently been conducted to develop a technique for preventing the increase in the threshold voltage V_{th} in a manner of shifting a negative threshold voltage V_{th} by applying a negative voltage as well as the data voltage V_{DATA} to the

[0017] As shown in FIG. 2, in the organic electro-luminescence pixel driving circuit including the two transistors TFT21 and TFT22 and the one storage capacitor C21, the OLED21 can be connected to an upper or lower end of the driving transistor TFT22.

[0018] One example of being connected to the upper end of the driving transistor TFT22 may include a Dual Plate OLED (DOD) structure. This structure is advantageous in that it is the simplest structure and also uses a Black Data Insertion (BDI) driving to effectively apply a negative voltage. Here, the BDI denotes that an emission-off interval is inserted in one frame in order to alleviate a TFT afterimage characteristic and improve a video image quality such as motion blur or the like.

[0019] However, in the related art organic electro-luminescence display device, upon applying a negative voltage to the gate node of the driving transistor, if a sufficient time was not given within one frame interval, the effect of preventing the increase in the threshold voltage was decreased.

[0020] In addition, since a driving data voltage relatively increased in order to enhance a deterioration compensation of the transistor, it was difficult to prevent the increase in the threshold voltage.

SUMMARY OF THE INVENTION

[0021] Accordingly, the present invention is directed to a driving apparatus for an organic electro-luminescence display device that substantially obviates one or more of the problems due to limitations and disadvantages of the related art.

[0022] An advantage of the present invention is to detect a shift of a threshold voltage of a driving transistor due to the deterioration of the driving transistor in a pixel driving circuit of an organic electro-luminescence display device, and also to compensate for a data voltage in cooperation with the detected result.

[0023] Another advantage of the present invention is to detect the shift of a threshold voltage of a driving transistor during a period other than an emission period by using a sensing line and switching transistors in a pixel driving circuit of an organic electro-luminescence display device.

[0024] To achieve these and other advantages and in accordance with the purpose of the present invention, as embodied and broadly described herein, there is provided a pixel driving apparatus of an organic electro-luminescence display device, the apparatus including a display controller configured to output a certain image signal to a data driving unit in a detection mode, detect an output voltage of the data driving unit, and operate a shifted degree of a threshold voltage of a corresponding driving transistor on a pixel driving circuit, thus to obtain a compensation value according to the shifted degree, such that upon outputting the image signal in an emission mode, the image signal can be compensated for based upon the compensation value for output, and a pixel driving circuit including a switching transistor configured to supply a data voltage or current inputted from the data driving unit in the detection mode to an organic light emitting diode driving transistor.

[0025] It is to be understood that both the foregoing general description and the following detailed description are exemplary and explanatory and are intended to provide further explanation of the invention as claimed.

BRIEF DESCRIPTION OF THE DRAWINGS

[0026] The accompanying drawings, which are included to provide a further understanding of the invention and are incorporated in and constitute a part of this specification,

illustrate embodiments of the invention and together with the description serve to explain the principles of the invention. In the drawings:

[0027] FIG. 1 is a block diagram of an organic electro-luminescence display device according to the related art;

[0028] FIG. 2 is a view showing a driving circuit of pixels arranged on the organic electro-luminescence display panel of FIG. 1;

[0029] FIG. 3 is a waveform view of scan signal and data voltage of FIG. 2;

[0030] FIG. 4 is a block diagram showing a pixel driving apparatus of an organic electro-luminescence display device in accordance with one exemplary embodiment of the present invention;

[0031] FIG. 5 is a block diagram showing a pixel driving apparatus of an organic electro-luminescence display device in accordance with another exemplary embodiment of the present invention;

[0032] FIGS. 6a and 6b are views showing on and off equivalent circuits according to switching operations of transistors in a voltage programming type driving circuit of FIG. 4;

[0033] FIG. 7 is a view showing a driving timing of the pixel driving circuit;

[0034] FIGS. 8a and 8b are views showing on and off equivalent circuits according to switching operations of transistors in a current programming type driving circuit of FIG. 5;

[0035] FIGS. 9(a) to 9(e) are views showing driving timings of a display panel in accordance with the present invention;

[0036] FIG. 10 is a view showing a pixel driving circuit including a switching transistor for blocking the supply of a high power voltage;

[0037] FIG. 11 is a view showing a basic pixel driving circuit in accordance with another exemplary embodiment of the present invention;

[0038] FIG. 12 is a view partially showing a display panel to which the another exemplary embodiment is applied;

[0039] FIG. 13a is a timing view of a programming period of FIG. 11;

[0040] FIG. 13b is a timing view of a current sensing in a detection mode; and

[0041] FIG. 14 is a schematic view of a screen indicating BDI intervals having the present invention applied thereto.

DETAILED DESCRIPTION OF THE INVENTION

[0042] Reference will now be made in detail to embodiments of the present invention, examples are illustrated in the accompanying drawings.

[0043] FIG. 4 is a block diagram showing a pixel driving apparatus of an organic electro-luminescence display device in accordance with one exemplary embodiment of the present invention.

[0044] As shown in FIG. 4, a pixel driving apparatus in accordance with one exemplary embodiment includes a display controller 41 configured to output a preset image signal DATA in a detection mode, detect a voltage outputted to a pixel driving circuit 43 from the data driving unit, operate the shifted degree of a threshold voltage of a corresponding driving transistor, and accordingly obtain a compensation value, such that when outputting an image signal DATA corresponding to original video data inputted from the exterior during an emission period, the image signal DATA is compensated for

based upon the compensation value for output, a data driving unit 42 configured to generate a data voltage V_{DATA} corresponding to the image signal DATA inputted from the display controller 41 and output the generated data voltage V_{DATA} to the pixel driving circuit 43, and the pixel driving circuit 43 configured to transfer the data voltage V_{DATA} from the data driving unit 42 to the driving transistor TFT43 such that the shifted degree of the threshold voltage of the driving transistor can be detected in the detection mode, and to allow the organic light emitting diode (OLED) of the corresponding pixel to emit light responsive to the data voltage V_{DATA} inputted from the data driving unit 42 in an emission mode.

[0045] The display controller 41 includes a modulator 41A configured to output a preset image signal DATA in a detection mode in which a target OLED is turned off and compensate for the image data DATA for output based upon a compensation value stored in a lookup table 41D in an emission mode, an analog/digital (A/D) converter 41B configured to convert the data voltage V_{DATA} outputted from the data driving unit 42 in the detection mode into a digital signal, and an operator 41C configured to compare a voltage value converted into the digital signal with a pre-stored reference value to operate the shifted degree of a threshold voltage V_{th} of the driving transistor based upon the comparison result, and store a compensation value corresponding to the shifted degree in the lookup table 41D.

[0046] The pixel driving circuit 43 includes a switching transistor TFT41 driven by a scan signal SCAN supplied via a scan line and configured to transfer a data voltage V_{DATA} supplied via a data line to the storage capacitor C41, a switching transistor TFT42 driven by the scan signal SCAN in the detection mode to transfer the data voltage V_{DATA} supplied via the data line to a drain of a driving transistor TFT43 which will be explained later, the storage capacitor C41 connected between a gate terminal of the driving transistor TFT43 and a terminal for a low power voltage V_{ss} to charge the data voltage V_{DATA} , the driving transistor TFT43 configured to supply a driving current corresponding to the data voltage V_{DATA} charged in the storage capacitor C41 to an organic light emitting diode OLED41, and the OLED41 having an anode connected to a terminal for a high power voltage VDD and a cathode connected to the drain of the driving transistor TFT43 to emit light with a brightness corresponding to the driving current.

[0047] FIG. 5 is a block diagram showing a pixel driving apparatus of an organic electro-luminescence display device in accordance with another exemplary embodiment of the present invention.

[0048] As shown in FIG. 5, a pixel driving apparatus in accordance with another exemplary embodiment includes a display controller 51 configured to output a preset image signal DATA in a detection mode, detect a voltage outputted to a pixel driving circuit 53 from the data signal DATA, operate the shifted degree of a threshold voltage of a corresponding driving transistor, and accordingly obtain a compensation value, such that when outputting an image signal DATA corresponding to original video data inputted from the exterior in an emission mode, the image signal DATA is compensated for based upon the compensation value for output, a data driving unit 52 configured to generate a data current I_{DATA} corresponding to the image signal DATA inputted from the display controller 51 and output the generated data current I_{DATA} to the pixel driving circuit 53, and the pixel driving circuit 53 configured to allow the organic light emitting diode (OLED) of the corresponding pixel to emit light responsive to the data current I_{DATA} inputted from the data driving unit 52.

[0049] The display controller 51 includes a modulator 51A configured to output a preset image signal DATA in a detection mode in which a target OLED is turned off and thereafter compensate for the image data DATA based upon a compensation value stored in a lookup table 41D in an emission mode, an analog/digital (A/D) converter 51B configured to convert a voltage V_{det} which is outputted from the data driving unit 52 in the detection mode and set on the pixel driving circuit 53, into a digital signal, and an operator 51C configured to compare the voltage value converted into the digital signal with a pre-stored reference value to operate the shifted degree of a threshold voltage V_{th} of the driving transistor based upon the comparison result, and store a compensation value corresponding to the shifted degree in the lookup table 51D.

[0050] The pixel driving apparatus of the organic electro-luminescence display device according to the present invention can be applied both to the voltage programming type pixel driving circuit and the current programming type pixel driving circuit as shown in FIGS. 4 and 5. Hereinafter, driving methods of the pixel driving circuits will be described.

[0051] First, FIGS. 6a and 6b are views showing on and off equivalent circuits according to switching operations of the switching transistor TFT41 and the sensing switching transistor TFT42 in the voltage programming type pixel driving circuit 43 of FIG. 4, and FIG. 7 is a view showing a driving timing of the pixel driving circuit 43.

[0052] Instead of supplying a high power voltage VDD to the anode of the OLED41 during one frame, the supply of the high power voltage VDD is blocked during a data programming period or data address period P1 (hereinafter, referred to as 'programming period') of the one frame. Under this state, positive scan signals SCAN1~SCANn are sequentially supplied to each horizontal line.

[0053] The switching transistor TFT41 is turned on by the corresponding scan signal SCAN during the programming period P1. Accordingly, the data voltage V_{DATA} supplied via the corresponding data line is charged in the storage capacitor C41 via the switching transistor TFT41 so as to be maintained until before an emission period P2. Simultaneously, the switching transistor TFT42 is turned on by a scan signal SCAN supplied to a gate of the switching transistor TFT41. This is for supplying a sensing current in order to compensate for a threshold voltage as will be explained later. Thus, it may not otherwise affect the programming of the data voltage.

[0054] Therefore, the pixel driving circuit 43 of FIG. 4 is configured in the programming period P1 as an equivalent circuit of FIG. 6a, for example.

[0055] Here, the data voltage V_{DATA} charged in the storage capacitor C41 is supplied to the gate of the driving transistor TFT43 and accordingly the driving transistor TFT43 is turned on. However, since the high power voltage VDD has been blocked from being supplied to the anode of the OLED41 as described above, a driving current I_{OLED} of the OLED41 becomes 0.

[0056] However, the data voltage V_{DATA} is supplied to the drain of the driving transistor TFT43 via the switching transistor TFT42, so as to flow a driving current as represented by [Formula 1] as follows.

$$I_{TFT} = \frac{1}{2} \cdot \frac{W}{L} \cdot C_{SIN} \cdot (V_{DATA} - V_{SS} - V_{TH})^2 \quad [\text{Formula 1}]$$

[0057] Afterwards, upon reaching the emission period P2, the switching transistor TFT41 is turned off, and thusly the gate node is in an electrically floating state. Thus, the pixel

driving circuit 43 of FIG. 4 can be configured in the emission period P2 as an equivalent circuit of FIG. 6b, for example.

[0058] Here, the high power voltage VDD is supplied to the anode of the OLED41 during the emission period P2.

[0059] Since the data voltage V_{DATA} stored in the storage capacitor C41 is being supplied to the gate of the driving transistor TFT43, the driving transistor TFT43 is turned on. Accordingly, a current flows toward a terminal for a low power voltage Vss via the OLED41 and the driving transistor TFT 43, such that the OLED 41 can emit light.

[0060] Here, the Vss wire on the display panel 40 has a resistance element. Accordingly, a potential of the low power voltage Vss is risen due to the flow of the current via the Vss wire, which is referred to as a Vss rising.

[0061] However, in the pixel driving apparatus of the present invention, when the potential of the low power voltage Vss is risen, the gate node of the driving transistor TFT43 is coupled by the storage capacitor C41, by which the voltage of the gate node is equally risen. Accordingly, the problem of the potential rising of the low power voltage Vss can be solved. A driving current of the OLED41 during the emission period P2 can be represented by [Formula 2] as follows.

$$I_{OLED} = \frac{1}{2} \cdot \frac{W}{L} \cdot C_{SINx} \cdot \{(V_{DATA} + \Delta V_{SS}) - (V_{SS} + \Delta V_{SS}) - V_{TH}\}^2 = \frac{1}{2} \cdot \frac{W}{L} \cdot C_{SINx} \cdot \{V_{DATA} - V_{SS} - V_{TH}\}^2 \quad [\text{Formula 2}]$$

[0062] FIGS. 8a and 8b are views showing on and off equivalent circuits according to switching operations of the switching transistors TFT41 and TFT42 in the voltage programming type driving circuit 53 of FIG. 5.

[0063] Instead of supplying a high power voltage VDD to the anode of the OLED41 during one frame, the supply of the high power voltage VDD is blocked during the programming period P1 of the one frame. Under this state, positive scan signals SCAN1~SCANn are sequentially supplied to each horizontal line.

[0064] The switching transistor TFT41 is turned on by the corresponding scan signal SCAN during the programming period P1. Accordingly, the data current I_{DATA} supplied via the corresponding data line is transferred to the storage capacitor C41 via the switching transistor TFT41, such that a voltage V_{DATA} having a level for allowing the data current I_{DATA} is set so as to be maintained until before an image period P2. Simultaneously, the switching transistor TFT42 is turned on by a scan signal SCAN supplied to the switching transistor TFT41. This is for supplying a sensing current in order to compensate for a threshold voltage as will be explained later. Thus, it may not otherwise affect the programming of the data voltage.

[0065] Therefore, the pixel driving circuit 53 of FIG. 5 is configured in the programming period P1 as an equivalent circuit of FIG. 8a, for example.

[0066] Here, the data voltage V_{DATA} charged in the storage capacitor C41 is supplied to the gate of the driving transistor TFT43 by the data current I_{DATA} to thusly turn the driving transistor TFT43 on. However, since the high power voltage VDD has been blocked from being supplied to the anode of the OLED41 as described above, a driving current I_{OLED} of the OLED41 becomes 0.

[0067] However, the data current I_{DATA} is supplied to the drain of the driving transistor TFT43 via the switching transistor TFT42, so as to flow a driving current as represented by [Formula 3] as follows.

$$I_{OLED} = 0 \quad [\text{Formula 3}]$$

$$I_{TFT} = I_{DATA} = \frac{1}{2} \cdot \frac{W}{L} \cdot C_{SINx} \cdot \{V_{DATA} - V_{SS} - V_{TH}\}^2$$

$$\text{here, } V_{DATA} = \sqrt{\frac{I_{DATA}}{k}} + V_{SS} + V_{TH}$$

[0068] Afterwards, upon reaching the emission period P2, the switching transistor TFT41 is turned off, and thusly the gate node is in an electrically floating state. Thus, the pixel driving circuit 53 of FIG. 5 can be configured in the emission period P2 as an equivalent circuit of FIG. 8b, for example.

[0069] Here, the high power voltage VDD is supplied to the anode of the OLED41 during the emission period P2.

[0070] Since the data voltage V_{DATA} stored in the storage capacitor C41 is being supplied to the gate of the driving transistor TFT43, the driving transistor TFT43 is turned on. Accordingly, a current flows toward a terminal for a low power voltage Vss via the OLED41 and the driving transistor TFT43, such that the OLED 41 can emit light.

[0071] Here, the Vss wire on the display panel 40 contains a resistance element. Accordingly, a potential of the low power voltage Vss is risen due to the flow of the current via the Vss wire, which is referred to as a Vss rising.

[0072] However, in the pixel driving apparatus of the present invention, when the potential of the low power voltage Vss is risen, the gate node of the driving transistor TFT43 is coupled by the storage capacitor C41, by which the voltage of the gate node is equally risen. Accordingly, the problem of the potential rising of the low power voltage Vss can be solved. A driving current of the OLED41 during the emission period P2 can be represented by [Formula 4] as follows.

$$I_{OLED} = \frac{1}{2} \cdot \frac{W}{L} \cdot C_{SINx} \cdot \{(V_{DATA} + \Delta V_{SS}) - (V_{SS} + \Delta V_{SS}) - V_{TH}\}^2 = \frac{1}{2} \cdot \frac{W}{L} \cdot C_{SINx} \cdot \{V_{DATA} - V_{SS} - V_{TH}\}^2 \quad [\text{Formula 4}]$$

[0073] However, in case of employing the method for driving pixels commonly using the terminal for the high power voltage VDD as mentioned above, a time excluding the programming period P1 of the one frame is determined as the emission period P2, namely, a lighting time of the OLED41, which may cause the lighting time of the OLED41 to be shortened.

[0074] Since a small display panel 40 uses a relatively small number of scan lines, even if pixels are driven by commonly using the terminal for the high power voltage VDD as mentioned above, the programming period P1 may not otherwise be affected and accordingly the lighting time of the OLED41 can be ensured.

[0075] However, a large display panel 40 (e.g., the number of scan lines: 768) has a relatively great number of scan lines. In case of driving it in the above manner, the programming period P1 is lengthened relatively long, it is difficult to ensure

the lighting time of the OLED41 as long as being required, thereby causing a brightness flicker.

[0076] Thus, a method by which the programming period P1 and the lighting time of the OLED41 can sufficiently be ensured, regardless of the small or large display panel 40, is proposed, which will be described with reference to FIG. 9.

[0077] The display panel 40 is configured such that a plurality of display panel regions are defined in a horizontal direction so as to include a plurality of neighboring scan lines, pixels within each display panel region defined are thusly allowed to share a corresponding power voltage among high power voltages [VDD.01~VDD.10], which are diverged and supplied from a terminal for the high power voltage VDD, and a programming period P1 and an emission period P2 are determined within a frame period by each defined display panel region.

[0078] In this case, wiring formats of scan lines S1~Sn and data lines D1~Dm within the display panel 40 are the same as those within a typical display panel.

[0079] However, the display panel 40 is configured such that a plurality of display panel regions are defined in the horizontal direction so as to include a plurality of neighboring scan lines (or horizontal lines), and the high power voltages VDD.01~VDD.10 are supplied to each defined display panel region.

[0080] As one example thereof, a large display panel 40 including 600 scan lines S1~Sn can be defined to have 10 display panel regions. Here, each of the 10 display panel regions is defined to include 60 scan lines (e.g., S1~S60, S61~S120, . . . , S54~S600).

[0081] For reference, since the display panel 40 to which the present invention is applied has been illustrated as an XGA (extended graphics array) display panel (i.e., 1024×768), 768 scan lines S1~Sn are required. However, for the sake of brief explanation, an example including 600 scan lines is disclosed.

[0082] Also, even within the plurality of the display panel regions defined in the horizontal direction, the terminal for the high power voltages VDD.01~VDD.10 is diverged into plural terminals so as to be connected to the corresponding power voltage terminals, respectively. For example, the terminal for the high power voltages VDD.01~VDD.10 is diverged into 60 power terminals within a first display panel region according to the above method, so as to be connected to the corresponding power voltage terminals, respectively.

[0083] FIGS. 9(a) to 9(e) show timings of the programming period P1, the emission period P2, the scan signals SCAN.001~SCAN.600 and the data voltage V_{DATA} within each display panel region to which each high power voltage VDD.01~VDD.10 which has been defined as shown above is supplied.

[0084] In other words, FIGS. 9(a) and 9(b) show exemplary programming period P1 and emission period P2 set for each display panel region. That is, in case of 10 display panel regions being defined for the display panel 40, one frame is divided among the ten such that the period of one-tenth frame is set to the programming period P1 of each display panel region and the rest period of nine-tenth frame is set to the emission period P2.

[0085] FIGS. 9(c) and 9(d) show timings of scan signals SCAN.001~SCAN.600 for each display panel region, by which it can be seen that such timings are the same to the typical scan timing.

[0086] FIG. 9(e) shows a timing of the data voltage V_{DATA} supplied to each display panel region, as a target, via the data lines D1~Dm. It can also be noticed that such timing in FIG. 9(e) is the same to the typical scan timing.

[0087] Here, for example, upon blocking the high power voltage VDD.01 of a first display panel region, the scan signal SCAN.001~SCAN.600 is supplied so as to program the data voltage on the first display panel region. Afterwards, at the same time of supplying the high power voltage VDD.01, an emission for the first display panel region is executed. Such programming and emission can be executed in the same manner for the next display panel region.

[0088] Accordingly, the current amount managed by the terminal for each high power voltage VDD.01~VDD.10 can be drastically reduced, and also a time for the emission can sufficiently be ensured.

[0089] In the above description, several methods may be employed to block the supply of the high power voltage VDD such that a current cannot flow via the OLED41 and the driving transistor TFT43 during the programming period P1 of one frame. One exemplary method implemented by using a switching transistor is illustrated in FIG. 10.

[0090] That is, drain and source of the switching transistor TFT44 are connected between the cathode of the OLED41 and the drain of the driving transistor TFT43. The display controller 41 then outputs a 'low' switching control signal EMS to the gate of the switching transistor TFT44 during the programming period P1 so as to turn the switching transistor TFT44 off.

[0091] As such, the description has been given of the driving method of solving a problem that Vss potential is risen in the voltage programming type pixel driving circuit 43 and the current programming type pixel driving circuit 53 both having the present invention applied.

[0092] Hereinafter, detailed description will be made of a process in which the shift of threshold voltages V_{th} of driving transistors of the voltage programming type pixel driving circuit 43 and the current programming type pixel driving circuit 53 in the pixel driving circuit, thus to compensate for data voltages according to the detection.

[0093] First, a process of detecting the shift of the threshold voltage V_{th} of the driving transistor TFT43 in the voltage programming type pixel driving circuit 43 in FIG. 4 so as to compensate for a data voltage V_{DATA} accordingly will be described.

[0094] The modulator 41A of the display controller 41 outputs a preset image signal DATA to the data driving unit 42 at a certain time (e.g., in a detection mode) when a target OLED41 on the pixel driving circuit 43 does not emit light.

[0095] Accordingly, the data driving unit 42 amplifies the voltage of the image signal DATA inputted from the modulator 41A via an operating amplifier OP1, thus to output the amplified voltage to the corresponding pixel driving circuit 43 via a resistance R1.

[0096] Here, the switching transistors TFT41 and TFT42 are all turned on by a scan signal SCAN. Accordingly, the data voltage V_{DATA} outputted from the data driving unit 42 is charged in the storage capacitor C41 via the switching transistor TFT41.

[0097] Since the driving transistor TFT43 is turned on by the data voltage V_{DATA} charged in the storage capacitor C41, a corresponding current I_{TFT43} then flows via the driving transistor TFT43 responsive to the data voltage V_{DATA} outputted from the data driving unit 42.

[0098] Here, an output terminal voltage V_{det} of the operating amplifier OP1 is converted into a digital signal in the A/D converter 41B. The output terminal voltage V_{det} of the operating amplifier OP1 then has a value obtained by multiplying the value of the current I_{TFT43} by the value of the resistance R1 (i.e., $V_{det} = I_{TFT43} \times R1$).

[0099] The operator 41C compares the voltage value converted into the digital signal with a pre-stored reference value, and operates the degree of deterioration of the driving transistor TFT43, namely, the degree of the shift of the threshold voltage V_{th} , based upon the comparison result. The operator 41C stores a compensation value corresponding to the operated degree of the shift in a lookup table 41D.

[0100] Afterwards, in an emission mode for outputting an image signal DATA corresponding to original video data from the exterior, the modulator 41A compensates for the image signal DATA based upon the compensation value stored in the lookup table 41D for output.

[0101] Accordingly, the data voltage V_{DATA} outputted from the data driving unit 42 is outputted as the compensated value corresponding to the shifted degree of the threshold voltage V_{th} of the driving transistor TFT43.

[0102] Therefore, even if the shift of the threshold voltage V_{th} of the driving transistor TFT43 occurs, the OLED41 can normally emit light by the compensation.

[0103] On the other hand, a process of detecting the shift of the threshold voltage V_{th} of the driving transistor TFT43 in the current programming type pixel driving circuit 53 in FIG. 5 so as to compensate for a data current I_{DATA} accordingly will be described as follows.

[0104] The modulator 51A of the display controller 51 outputs a preset image signal DATA to the data driving unit 52 at a certain time (e.g., in a detection mode) when a target OLED41 on the pixel driving circuit 53 does not emit light.

[0105] Accordingly, the data driving unit 52 outputs the current I_{DATA} corresponding to the image signal DATA inputted from the modulator 51A to the corresponding pixel driving circuit 53.

[0106] Here, the switching transistors TFT41 and TFT42 are all turned on by a scan signal SCAN. Accordingly, the data current I_{DATA} outputted from the data driving unit 52 is supplied to the storage capacitor C41 via the switching transistor TFT41, and the corresponding voltage is charged (set) in the storage capacitor C41.

[0107] The driving transistor TFT43 is then turned on by the voltage set in the storage capacitor C41. Here, the data current I_{DATA} outputted from the data driving unit 52 is transferred to the drain of the driving transistor TFT43 via the switching transistor TFT42, thereby allowing the flow of a corresponding current I_{TFT43} .

[0108] Here, the voltage set in the storage capacitor C41 is outputted as a detection voltage V_{det} to the output terminal of the data driving unit 52, thus to be converted into a digital signal in the A/D converter 51B. The operator 51C compares the voltage value converted into the digital signal with a pre-stored reference value, and operates the degree of deterioration of the driving transistor TFT43, namely, the shifted degree of the threshold voltage V_{th} , based upon the comparison result. The operator 51C stores a compensation value corresponding to the operated degree of the shift in the lookup table 51D.

[0109] Afterwards, in an emission mode for outputting the image signal DATA corresponding to original video data from the exterior, the modulator 51A compensates for the

image signal DATA based upon the compensation value stored in the lookup table 51D for output.

[0110] Accordingly, the data current I_{DATA} outputted from the data driving unit 52 is outputted as the compensated value corresponding to the shifted degree of the threshold voltage V_{th} of the driving transistor TFT43.

[0111] Therefore, even if the shift of the threshold voltage V_{th} of the driving transistor TFT43 occurs, the OLED41 can normally emit light by the compensation.

[0112] In the meantime, in another exemplary embodiment of the present invention, a separate current sensing line is provided and the current of a driving transistor on a pixel driving circuit is sensed by using a specific interval (time), such as a black data insertion (BDI). Based upon the sensed current, the shifted degree of the threshold voltage V_{th} of the driving transistor is analyzed as described above and compensated for. This is now described.

[0113] FIG. 11 shows a basic pixel driving circuit in accordance with another exemplary embodiment of the present invention. As shown in FIG. 11, a pixel driving circuit in accordance with another exemplary embodiment includes a switching transistor TFT22A turned on by a scan signal SCAN1 in a detection mode for detecting a programming period or the shifted degree of a threshold voltage of a driving transistor and configured to transfer a data voltage V_{DATA} supplied via a data line to a storage capacitor C22, a switching transistor TFT22B turned on by a scan signal SCAN2 in the detection mode and configured to transfer a sensing voltage supplied via a separately disposed sensing line to a drain of a driving transistor TFT22C, the storage capacitor C22 connected between a gate terminal of the driving transistor TFT22C and a terminal for a low power voltage V_{ss} and configured to charge the data voltage V_{DATA} , a driving transistor TFT22C configured to allow a driving current corresponding to the data voltage V_{DATA} charged in the storage capacitor C22 to be supplied to an OLED 22 in an emission mode, and configured to be driven by the charged data voltage V_{DATA} supplied to the gate and the sensing voltage supplied to the drain via the switching transistor TFT22B, and the OLED22 having an anode connected to a terminal for a high power voltage V_{DD} and a cathode connected to the drain of the driving transistor TFT22C and configured to emit light with a brightness corresponding to the driving current. Hereinafter, the operation of the pixel driving circuit in accordance with the another exemplary embodiment having such configuration will be described in detail with reference to FIG. 14.

[0114] The basic pixel driving circuit of the another exemplary embodiment is configured as shown in FIG. 11. Such pixel driving circuit is arranged on a display panel in a matrix. FIG. 12 shows part of the display panel. FIG. 13a is a timing view of a programming period of FIG. 11, and FIG. 13b is a timing view of a current sensing in a detection mode.

[0115] The programming operation using two transistors TFT22A and TFT22C and one storage capacitor C22 in each pixel driving circuit (e.g., PX22) is the same to that in a typical pixel driving circuit.

[0116] That is, as shown in FIG. 13a, 'high' scan signal SCAN1 and 'high' data voltage V_{DATA} are supplied during a programming period (or data address period). Accordingly, the switching transistor TFT22A is turned on, and thusly the data voltage V_{DATA} supplied via a data line is charged in the storage capacitor C22, so as to be maintained until before an emission period.

[0117] Afterwards, during the emission period, the driving transistor TFT22C is turned on by the data voltage V_{DATA} charged in the storage capacitor C22 such that a current as much as corresponding to the data voltage V_{DATA} can flow via the OLED22. Hence, the OLED22 can emit light with a brightness of the corresponding current amount.

[0118] On the other hand, a current of the corresponding driving transistor is detected by selecting a pixel driving circuit by a certain period using a specific interval (time), such as the BDI. An example of detecting a current by selecting a pixel driving circuit PX22 will be described herein.

[0119] First, at a first step, a 'high' scan signal SCAN1.n+1 of a scan line and a scan signal SCAN2.n of another scan line are outputted for a BDI interval of one frame. Accordingly, switching transistors TFT21A and T22A of pixel driving circuits PX21 and PX22 are turned on, whereas switching transistors TFT11A and TFT12A of another pixel driving circuits PX11 and PX12 are turned off.

[0120] Here, 5V of data voltage $V_{DATA.m+1}$ of a data line is supplied, and 0V (or negative voltage) of data voltage $V_{DATA.m}$ of another data line is supplied. The voltage 5V is charged in the storage capacitor C22 of the pixel driving circuit PX22, and no voltage is charged in storage capacitors C11, C12 and C21 of the rest pixel driving circuits PX11, PX12 and PX21.

[0121] Afterwards, at a second step, a 'low' scan signal SCAN1.n+1 of the scan line is outputted so as to turn off the switching transistors TFT21A and TFT22A of the pixel driving circuits PX21 and PX22. Simultaneously, a 'high' scan signal SCAN2.n+1 of a scan line is outputted so as to turn on the switching transistors TFT21B and TFT22B.

[0122] Under this state, 15V of sensing signal SENSE of a sensing line is supplied. Accordingly, the 15V of sensing signal SENSE supplied via the sensing line is transferred to the drain of the driving transistor TFT22C via the switching transistor TFT22B of the pixel driving circuit PX22; however, it does not affect the rest of pixel driving circuits PX11, PX12 and PX21.

[0123] That is, in the pixel driving circuits PX11 and PX12, since the switching transistors TFT11B and TFT12B are turned off, the 15V of voltage supplied via the sensing line is not transferred to the drain of the driving transistors TFT11C and TFT12C. Also, in the pixel driving circuit PX21, since the switching transistor TFT21B is turned on but a gate voltage of the driving transistor TFT21C is 0V, the driving transistor TFT21C is maintained in a turn-off state.

[0124] Here, the OLED22 of the pixel driving circuit PX22 is turned off due to a reverse voltage or the blocking of the high power voltage VDD.

[0125] As a result, through such processes as described above, the driving transistor TFT22C of the pixel driving circuit PX22 is driven in the detection mode. Accordingly, the shift of the threshold voltage V_{th} is detected, as shown in FIGS. 4 and 5, via the sensing line, thus to be compensated for as much as being shifted.

[0126] FIG. 14 shows an exemplary interval, namely, BDI interval for analyzing the shifted degree of a threshold voltage V_{th} of a driving transistor in accordance with another exemplary embodiment of the present invention. Here, x-axis denotes an interval corresponding to a frame time, and y-axis denotes an interval for which a scan signal SCAN is supplied on a display panel. The BDI interval corresponds to 10% of one frame. During this BDI interval, an emission of the OLED is not executed. Thus, the number of detection of the

shift of the threshold voltage is determined according to a BDI driving method. For example, for a BDI of 9:1, the maximum number of pixels, for which the shift of the threshold voltage is detectable, is 10 per one frame. Hence, each pixel is sequentially selected by a certain period for each BDI of one frame, and at each selection, the shifted degree of the threshold voltage V_{th} of the corresponding driving transistor can be analyzed.

[0127] The present invention can advantageously improve the compensation for the deterioration of a driving transistor by detecting the shifted degree of a threshold voltage of the driving transistor due to the deterioration of the driving transistor in a pixel driving circuit of an organic electro-luminescence display device, and compensating a data voltage according to the detection result.

[0128] Also, in the pixel driving circuit of the organic electro-luminescence display device, the shift of the threshold voltage of a driving transistor can be detected at a period other than an emission period by using sensing line and switching transistors, so as to reduce power consumption.

[0129] It will be apparent to those skilled in the art that various modifications and variations can be made in the present invention without departing from the spirit or scope of the invention. Thus, it is intended that the present invention cover modifications and variations of this invention provided they come within the scope of the appended claims and their equivalents.

What is claimed is:

1. A pixel driving apparatus of an organic electro-luminescence display device comprising:

a display controller configured to output a certain image signal to a data driving unit in a detection mode, detect a voltage outputted from the data driving unit to a pixel driving circuit, and operate a shifted degree of a threshold voltage of a corresponding driving transistor, thus to obtain and store a compensation value, such that upon outputting the image signal corresponding to an original image signal inputted in an emission mode, the image signal is compensated for based upon the compensation value for output;

a data driving unit configured to generate a data voltage corresponding to data inputted from the display controller and output the generated data voltage to the pixel driving circuit; and

a pixel driving circuit including a switching transistor configured to transfer the data voltage inputted from the data driving unit to the driving transistor, such that the shifted degree of the threshold voltage of the driving transistor is detectable.

2. The apparatus of claim 1, wherein the display controller comprises:

a modulator configured to output a preset image signal in the detection mode and compensate for the image signal based upon a compensation value stored in a lookup table in the emission mode;

an analog/digital (A/D) converter configured to convert the data voltage outputted from the data driving unit in the detection mode into a digital signal; and

an operator configured to compare the converted value into the digital signal with a pre-stored reference value, operate the shifted degree of the threshold voltage of the driving transistor on the pixel driving circuit based upon the comparison result, and store a compensation value corresponding to the operation result in the lookup table.

3. The apparatus of claim 3, wherein the data driving unit is configured to generate a data voltage or data current corresponding to the image signal inputted from the display controller, thus to output to the pixel driving circuit.

4. The apparatus of claim 1, wherein the pixel driving circuit comprises:

a first switching transistor driven by a scan signal provided via a scan line and configured to transfer a data voltage provided via a data line to a storage capacitor;

a second switching transistor driven by the scan signal to transfer the data voltage provided via the data line to a drain of a driving transistor to be explained later in the detection mode;

a storage capacitor connected between a gate terminal of the driving transistor and a terminal for a low power voltage to charge the data voltage;

a driving transistor configured to provide a driving current corresponding to the data voltage charged in the storage capacitor to an organic light emitting diode; and

an organic light emitting diode having an anode connected to a terminal for a high power voltage and a cathode connected to the drain of the driving transistor, and configured to emit light with brightness in correspondence with the driving current.

5. The apparatus of claim 1, wherein the pixel driving circuits include a voltage programming type pixel driving circuit and a current programming type pixel driving circuit.

6. The apparatus of claim 1, wherein the pixel driving circuit is configured to block a high power voltage provided to the organic light emitting diode during a programming period so as to prevent the shift of a low power voltage.

7. The apparatus of claim 6, wherein a third switching transistor is used to block a high power voltage from being provided to the organic light emitting diode.

8. The apparatus of claim 7, wherein the third switching transistor is configured to be turned on by a switching control signal provided from the display controller.

9. A pixel driving apparatus of an organic electro-luminescence display device comprising:

a first switching transistor turned on by a first scan signal in a detection mode of detecting a data programming period or a shifted degree of a threshold voltage of a driving transistor, thus to transfer a data voltage provided via a data line to a storage capacitor;

a second switching transistor turned on by a second scan signal in the detection mode, thus to transfer a sensing voltage provided via a sensing line to a drain of the driving transistor;

a storage capacitor connected between a gate terminal of the driving transistor and a terminal for a low power voltage, thus to charge the data voltage in the data programming mode or the detection mode; and

a pixel driving circuit arranged on a display panel in a matrix and including the driving transistor configured to allow a driving current corresponding to the data voltage charged in the storage capacitor to be supplied to an organic light emitting diode in an emission mode, and driven by the charged data voltage and a sensing voltage provided to the drain via the second switching transistor, wherein the driving transistor, which is a target for detection in the detection mode, is connected to the sensing line and also driven by the data voltage and the second scan signal.

10. The apparatus of claim 9, wherein the sensing line is disposed to be connectable to a drain of a driving transistor of every pixel within a display panel so as to transfer the sensing voltage.

11. The apparatus of claim 9, wherein the detection mode is set within a black data insertion (BDI) interval.

* * * * *

专利名称(译)	用于有机电致发光显示装置的驱动装置		
公开(公告)号	US20090140959A1	公开(公告)日	2009-06-04
申请号	US12/289912	申请日	2008-11-06
[标]申请(专利权)人(译)	NAM宇进 JOO苏		
申请(专利权)人(译)	NAM , WOO-JIN JOO , IN-SU		
当前申请(专利权)人(译)	LG DISPLAY CO. , LTD.		
[标]发明人	NAM WOO JIN JOO IN SU		
发明人	NAM, WOO-JIN JOO, IN-SU		
IPC分类号	G09G3/30		
CPC分类号	G09G3/3233 G09G3/325 G09G3/3283 G09G2320/0295 G09G2300/0861 G09G2320/0285 G09G2300/0842		
优先权	1020070112916 2007-11-07 KR		
其他公开文献	US10089934		
外部链接	Espacenet USPTO		

摘要(译)

公开了一种防止由于有机电致发光显示装置中的驱动装置的劣化导致的图像质量劣化的装置。

